

NATO
Underwater Diving Working Group 2020

INDUSTRY SUPPORT



The Royal Crescent, Bath, UK

Due to the cancellation of the 2020 UDWG Industry Reception, Sonistics has produced this e-brochure showcasing the companies who have supported this event over the years.

We hope it will be possible to invite you to participate in an event in 2021





VIKING™ THE WORLDWIDE DIVING STANDARD

Diving is a hazardous occupation. That is why safety is the most important issue for us at Ansell when designing and producing VIKING™ diving suits. But isn't functionality as important? Of course – we see functionality as the most important aspect of safety.

A diving suit that works the way it should is perhaps the best safety assurance the professional diver can get. In fact we like to think of it as a standard. The worldwide diving standard.

For more information, visit
protective.ansell.com

Ansell

Rebreather Mode LW & LD

"You name the mission,
we'll name the rig"

Aqua Lung is the name that introduced the world to scuba diving in 1943, when Jacques-Yves Cousteau and Emile Gagnan developed the first regulator "aqualung", which expanded the possibilities of underwater exploration.

For over 70 years, our dedication to quality and innovation has led to the manufacture of the world's premier scuba diving equipment for professional and recreational use.

The Aqua Lung Group is composed by different manufacturer affiliates, each of them is focused on the design and assembly of a family of products.

Aqua Lung France - La Spirotechnique continues to specialize in underwater breathing apparatus such as regulators, rebreathers, cylinder valves, oxygen and mixed gas military diving equipment.

Design, development and assembly of diving breathing apparatus, Sales and After Sales services for the military & professional sector, are certified ISO 9001:2015



AQUA LUNG IS ALSO A COMPLETE REBREATHER RANGE



FROGS 18



AMPHORA 18



CRABE

Aqua Lung - La Spirotechnique IC
1^{ère} Avenue, 14^{ème} rue
CS 60 148 - 06513 Carros Cedex - France
Tel: +33 442 082 888 - Fax: +33 492 082 886

AQUA LUNG
Military & Professional

MCM100[™]

MULTI-ROLE REBREATHER

Full data recording

Multiple gas mixes

HUD - Green is good

Extremely low
work of breathing

Lowest through life cost

Low drag

Long endurance at
extreme work rates

Digital O₂ & CO₂ sensors

Multiple layers of
electronic redundancy

Automated pre-dive
sequence

Onboard decompression
monitoring

ADVANCE WITH CONFIDENCE



www.avon-protection.com

AVON
PROTECTION

COBHAM

Rebreather Diving Equipment

Viper Series MCM/EOD



Trusted around the World from the Arctic to the Equator

Cobham is the leading manufacturer of underwater military rebreathers including the low profile Viper series, with free swimming sets being ideally suited for MCM and rapid deployment operations.

www.cobham.com



Going under, Going PRO

De Zeeman Pro is a reliable partner for the purchase, maintenance, and repair of professional diving equipment. We specialize in equipment for commercial diving, military diving, life support and sports diving for companies, governments and consumers all over the world.

By constantly investing in our clients, our infrastructure, and our equipment, we aim to become one of the world's top companies. We are constantly expanding our range of products to meet the needs of our clients.

Our head office is located in Mechelen, Belgium. We operate internationally, and have offices in three countries (Belgium, France, and Germany), from where we serve our clients.



Belgium
 T +32 15 43 01 31
 F +32 15 43 01 35
 info@dezeeman.be

France
 T +33 4 83424595
 info@dezeeman.fr

Germany
 T +49 2605 962 60 13
 F +49 2605 962 60 14
 info@dezeeman.de

www.dezeeman.com



Dräger



**Safer diving, made easy –
LAR 8000 engineered with simplicity and safety in mind**

To accomplish a mission, you need to save your strength, time, and effort. This is why our newly designed rebreather offers you minimal breathing effort, minimal set-up time, with minimal training needed.

Every dive, no matter how specialised, is made easier with LAR 8000. You are able to focus clearly on the task at hand without worrying about your equipment. The LAR 8000 combines uncompromising safety with the highest level of breathing and carrying comfort. It withstands extreme use all the while providing you with effortless handling. To learn more, please visit www.draeger.com/LAR8000/UDWG

Dräger. Technology for Life®

18027

Connection for external gas supply either surface supplied or from cylinders, once connected it always becomes the ball out gas for the diver

The breathing circuit can be stored, under the cover, fully prepared for immediate use

The harness is ergonomically designed for enhanced comfort and safety

Divator Full Face Mask gives the diver good vision and excellent breathing comfort with both mouth and nose, crystal clear communication is possible with the design without mouthpiece

Standard version is rated for 60 m diving and the deep version can be used down to 120 m

The hinged bellows delivers the correct dosage of fresh gas directly linked to the diver's breathing and allows very easy breathing in any position

Breathable gas that can be used in an emergency

The IS-Mix™

A faster way to clear your mine

The slightest sound and magnetism when approaching a modern sea mine can trigger an explosion. It's for these circumstances we have created our semi-closed rebreather the IS-Mix. A perfectly balanced and complete mine clearance system with outstanding RAM* attributes. Being intuitive and fast to prepare, yet highly capable, the IS-Mix enables a diver to be in the water in less than 20 minutes. With supreme breathing and diving comfort the diver can operate in any orientation and, thanks to its low magnetic and acoustic signatures, swim to work undetected.

*Reliability, Availability, Maintenance



Confidence Under Pressure

JFD offers a comprehensive range of fully compatible Swimmer Delivery Vehicles and Rebreathers to meet the varied requirements and operational demands of today's defence divers.

JFD has identified the most effective and sustainable in-service support model and has developed a range of training solutions which have evolved over many years.



SWIMMER DELIVERY VEHICLES

JFD offers a range of Swimmer Delivery Vehicles (SDVs) to facilitate the insertion and extraction of Special Operations forces and equipment.

- **SEAL Carrier**
8-man vehicle which operates in three modes: surface, semi-submerged and submerged
- **Sub SEAL**
6-man fully submerged vehicle
- **Torpedo SEAL**
2-man fully submerged vehicle

JFD REBREATHERS

Low magnetic and acoustic, closed and semi-closed oxygen and nitrox rebreathers can be tailor made to user specification.

MCM

- Sea th CDL SF
- Sea th SO

Combat Diver / Special Operations

- Shadow Performer
- Shadow Excursion
- Shadow front and back mount variants

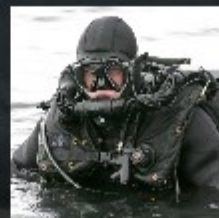

jfdglobal.com



ExtendAir® CO₂ absorbent cartridges are approved for use in combat diver rebreathers by the US Navy as well as several EU and Pac Rim countries' Special Forces.

Micropore, Inc. of Elkton, Maryland USA manufactures ExtendAir® CO₂ absorbent, a revolutionary absorbent technology for use in rebreathing and life support applications. ExtendAir® technology solves the safety, storage, and loading problems associated with traditional granular CO₂ absorbents.

ExtendAir® absorbent has many defense applications including use for military Special Operations and Mine Clearance rebreathers, emergency and primary atmospheric control on submarines, and medical oxygen delivery. Compared to the traditional granular carbon dioxide absorbents, ExtendAir® absorbent makes breathing up to 40% easier and provides up to 50% longer life support. Granule absorbents form a powder when subjected to the shocks and vibrations of regular transportation, storage, and in-use scrubbing. This powder creates a dangerous chemical dust and settling in the scrubber canister, shortening the scrubbers' duration and making breathing more difficult. ExtendAir® cartridges do not suffer from this type of degradation during transportation, storage or while in use due to its unique, patented material properties. In addition, ExtendAir® absorbents for rebreathers offer an initial water tolerant solution, significantly reducing 'caustic cocktail' when compared to all other absorbents. Operationally, it is superior since it takes mere seconds to load, reduces training time, is more reliable, and its single-use packaging eases deployment logistics.

The absorbent is FDA approved for oxygen delivery systems. In addition, ExtendAir® absorbents are the chosen standard for emergency life support on submarines and are currently in service with international navies including Canada, Greece, Italy, Netherlands, Singapore, Indonesia, South Korea, Sweden, Turkey, US, and the UK.

Micropore is pleased to announce that the Avon MCM100, Aqualung FROGS, AMPHORA, MODE, JFD Shadow Enforcer, Drager MK25, and Open Safety Incursion rebreathers have absorbent solutions integrated and for sale. For Aqualung FROGS/AMPHORA and Drager units, the retrofit is a direct drop-in replacement to the granule canister. No modifications needed. The Avon MCM100, JFD Enforcer, Aqualung MODE and Open Safety Incursion units are supplied with integrated canister solutions for the ExtendAir® cartridge.



Aqualung MODE



Avon MCM100



JFD Enforcer



ExtendAir® LAR-V/MK25 Retrofit Kit

We are working with the world's leading rebreather manufacturer's, integrating ExtendAir® CO₂ absorbent systems. **Contact: Mr. Rick Oddo, +1.443.245.4124: Rick.Oddo@microporeUSA.com www.extendairusa.com**

NAUTIL
UNDERWATER SYSTEMS



SCULE®

NAUTIL
UNDERWATER SYSTEMS

☎ COUTANCIN Sebastien
☎ +33 (0)6 41 07 78 30
✉ contact@nautil-u-s.fr

inkblue

NAUTIL UNDERWATER SYSTEMS - CONTACT@NAUTIL-U-S.FR - 06 41 07 78 30

SCULE®

SELF-CONTAINED UNDERWATER LIFTING EQUIPMENT

The SCULE is a new concept of underwater lifting, thanks to its patented innovations. It's safer, more reliable, lighter, and more ergonomic than any existing assembly, and it considerably reduces the intervention time.

Ordnance disposal operations, remote or in zero visibility lifting operations; pre-positioned equipment recovery, underwater engineering, R.O.V. operations... The SCULE can easily be used by a single diver or by R.O.V. It is fully flexible and adaptable to all your needs.



- 2 sizes of cylinder kits available :
4M³ (140ft³) / 7M³ (250ft³)
- 2 interchangeable lifting bags :
500Kg (1100Lbs) / 1000Kg (2200Lbs)

- Available options :
 - ☑ Programmable timing for arming or actuation
 - ☑ Towing and Remote actuation Line
 - ☑ Acoustic actuation
(Available in 2020)
 - ☑ Pocket for 10 to 15 meters of additional lift line
 - ☑ Many accessories according to your needs



Programmable timing for arming or actuation



Towing and Remote actuation Line

EXAMPLE KITS (INDICATIVE DATA)



KIT		4M ³ / 500KG	7M ³ / 1000KG
Weight	Empty	<25Kg (<55Lbs)	<40Kg (<88Lbs)
	Ready to use	<30Kg (<66Lbs)	<50Kg (<110Lbs)
	In fresh water	-1Kg (-2Lbs)	-1Kg (-2Lbs)
Maximum Depth		200m (650ft)	200m (650ft)
Lift capacity	At 50m (160ft)	500Kg (1100Lbs)	1000Kg (2200Lbs)
	At 80m (260 ft)	400Kg (880Lbs)	750Kg (1650Lbs)
	At 200m (650 ft)	180Kg (400Lbs)	330Kg (720Lbs)



LEPTONIX
FOR THOSE WHO DARE.



PD² TECHNOLOGY - PROFESSIONAL DIVING GOODS

PD² Technology GmbH - Carhard-Falk-Straße 5 - D-21035 Hamburg - professionals@pd2.technology - www.pd2.technology



MIREB MK1

**UNDERWATER REBREATHER
FOR PROFESSIONAL AND MILITARY USE**
CE 14143:2013 Rina Services Spa- Ansti Test Ltd

*Mechanical CCR
SCRActive flow
SCRPassive flow and Mechanical Self-Mix*



**MIREB MK1 USES WATERTIGHT CASES EXPLORER GT-LINE SRL
GT-LINE IS A COMMERCIAL PARTNERSHIP OF S.A.R.A. Srl**

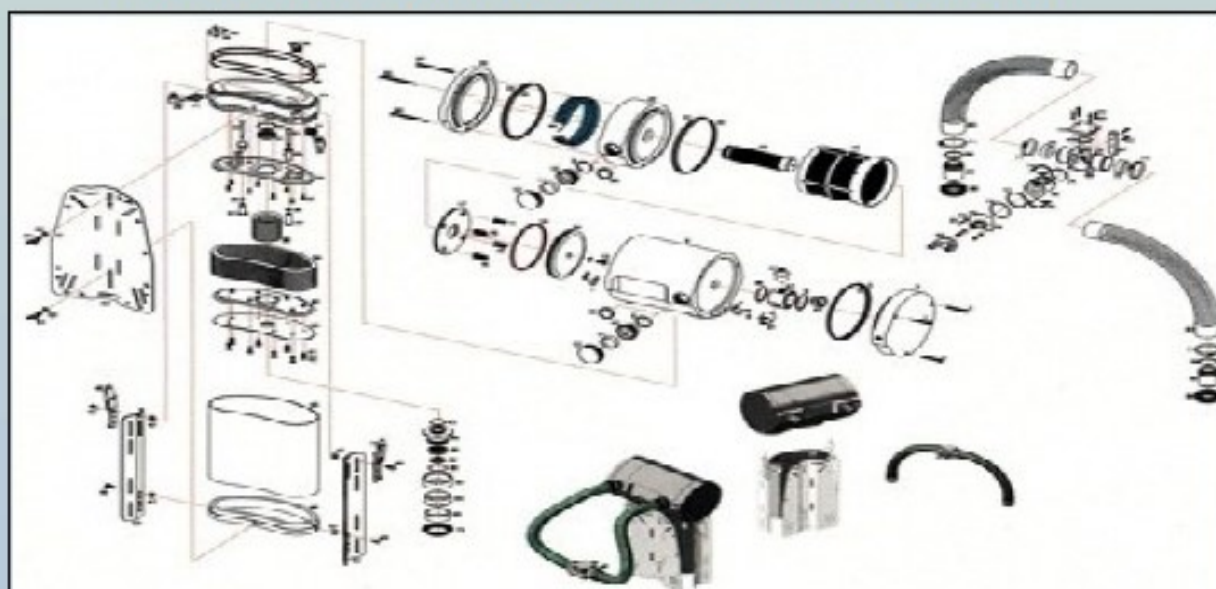

www.saraservicemilano.com



Traditionally innovative

As one of the global market and technology leaders in the development and production of high-pressure compressors, systems and accessories for armies, air forces and navies, Sauer Compressors delivers top-of-the-line compressor systems for defence applications.

At the heart of every Sauer breathing air station is a robust compressor block designed to withstand the highest demands occurring in naval applications, e.g. shock, vibration, inclination, high temperatures and continuous operation. Our naval breathing air compressors – from TORNADO, HURRICANE and 5000 series – can be delivered to comply with various shock and vibration standards ranging from simple LRoS rules to the ultimate naval standards, such as US Mil Std 901 or German BV0432 and 044. The vertical design of the TORNADO and 5000 series ensures the smallest footprint in combination with lowest noise emissions and structure-borne noise.

All Sauer breathing air compressors are available with everything required for a complete installation: fully automatic electronic control, noise insulation down to 72 db(A), integrated filter, demistor and condensate collecting tank. Filtration can be delivered according to all international standards such as **DIN EN 12021**, **BS 4275** and **BS 4001** or **US CGA Grade D+E** and Navy standard **FS Grade A+B**. In addition a real-time breathing air monitoring system is available, state-of-the-art gas analysis systems in compliance with **BS EN 12021:2014**, **DEF STAN 68284** and worldwide military standards.

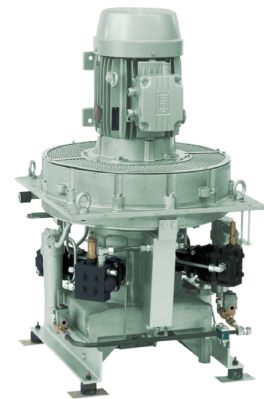

Tornado

TORNADO WP 4325

Max. final pressure: 350 barg

Charging rate: 400 – 600 l/min

ABOUT SAUER COMPRESSORS

Sauer Compressors is a medium-sized group of companies headquartered in Kiel, Germany. Founded in 1884, it now focuses on the development, production and sale of oil-lubricated and oil-free medium- and high-pressure compressors for applications in the defence, commercial shipping, general industry and petro industry sectors. Its modern reciprocating compressors for both air and a wide range of gases deliver pressures of 1 to 500 barg.

J.P. Sauer & Sohn Maschinenbau GmbH
www.sauercompressors.com

Dependable up to 500 bar – anywhere, anytime, anygas.



**Wireless communication between a distressed submarine
surface assets
rescue submersibles
divers**



**In service with the Italian Navy and the Royal Australian Navy
NSN: 5845-15-000-4726**

www.sonistics.com



M47

WATERPROOF MILITARY DRYSUIT FAMILY

